



SIEMENS

Answers for Energy

Centrifugal Turbocompressors

Single-stage integrally geared (STC-GO)

www.siemens.com/energy

500KG

3106

SIEMENS

8083

804r

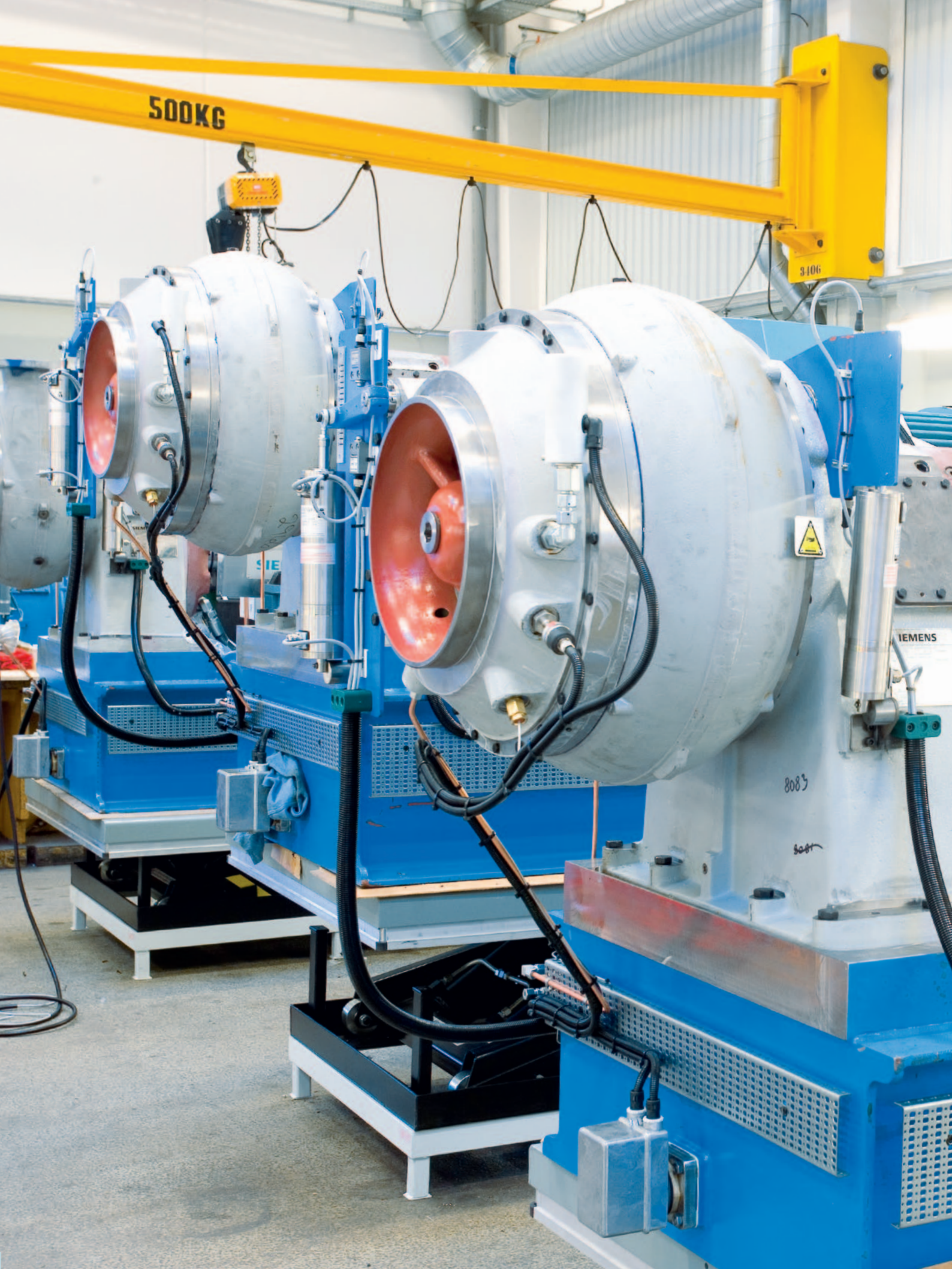

Highest efficiency, compact design

Siemens designs and manufactures high-performance aeration technology for municipal wastewater treatment and industrial applications.

The efficient STC-GO compressors are made uniquely according to plant specifications thereby consuming significantly less energy compared to other compressor designs. The high quality compressor components and the conformity with technical standards for a broad range of applications ensure long-term reliability and minimum maintenance.

With more than 7,000 of units operating worldwide, Siemens has become the market leader within its specific application areas.

The manufacturing site of the Siemens STC-GO compressors is together with our research and development center located in Helsingør/Denmark. Here our highly skilled production workers, dedicated engineers and biological experts are constantly improving compressor technologies, while keeping a main focus on optimized efficiency and less energy consumption.

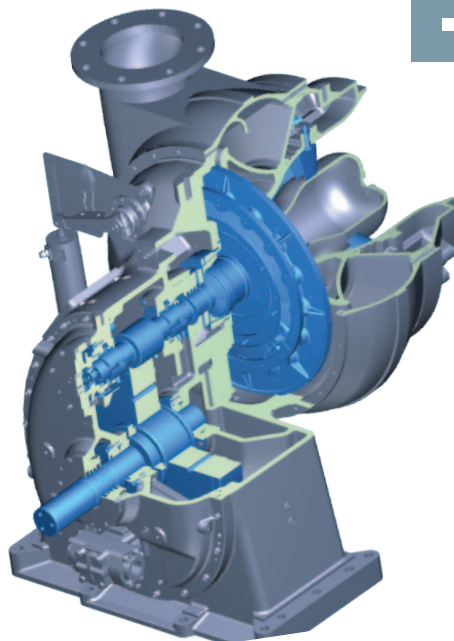

Highlights

- Highest efficiency is automatically and continuously maintained over the entire turndown range, including off-design ambient temperatures and pressures where units most often operate
- **Turndown to 45 % (or less)** at constant speed
- **Variable flow** by means of variable vane diffusers, pre-rotational inlet guide vanes or a combination of both systems, the Dual-Point-Control™
- **High-quality bearing construction** results in exceptionally long life with minimal maintenance
- **Guaranteed oil-free air delivery**
- **Compact design** saves floor space and facilitates the replacement of older, less efficient compressors
- Standard or **tailor made Instrumentation** and control for compressor operation compressor operation.
- **Low noise level** with no pressure pulsation
- **Low operating and maintenance costs**

Siemens Turbocompressors (STC) for Aeration

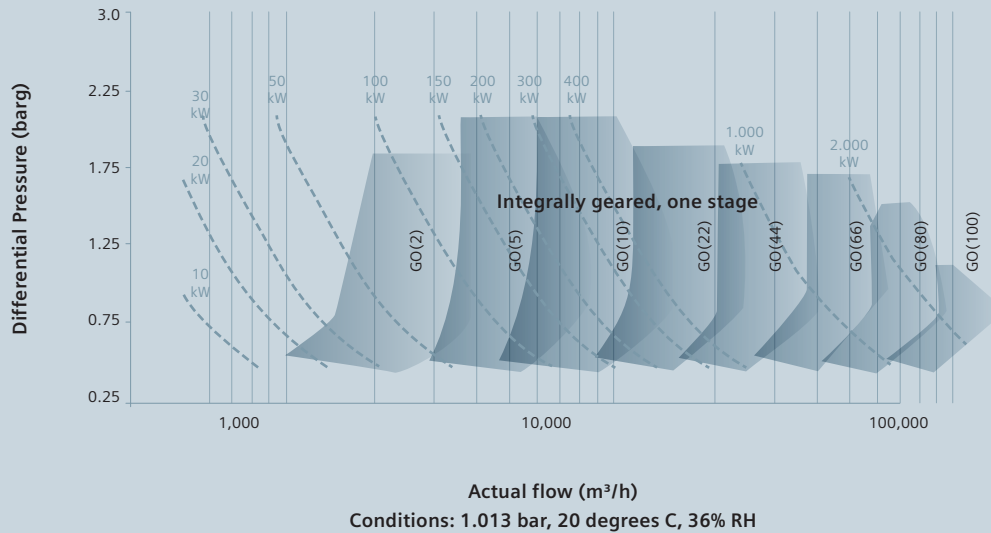

STC-GO product range

Fields of application

Wastewater treatment

Biological treatment of effluent in:

- Municipal sewage
- Industrial sewage

Flue gas desulfurization

Oxidation air blowers associated with the cleaning of flue gases produced within power and heavy industry.

Fermentation and enzyme production

Biochemical treatment within pharmaceutical and yeast production industry and similar biological processes

Pulp and paper processes

Furnaces and smelters

Air blowers providing combustion or reaction air primarily for the petrochemical and metals industries.

Sulphur recovery

Air blowers providing reaction air for the catalytic recovery of sulphur within the petrochemical industry.

Compressor flow and pressure range

Flow and pressure range from 1,000 to 125,000 Nm³. Differential pressure up to 2.5 bar (up to 4 bar possible with two stage design).

The Siemens STC-GO compressor series for municipal and industrial applications is comprised of different sizes. Siemens offers a complete package consisting of an integrated gearbox, coupling, electric motor and lube oil system, all mounted on a common base frame.

Efficiency by design

The Siemens STC-GO compressor has an advanced mechanical & aero-dynamical design and cutting edge control system. The air-end and integral gearbox have been developed and evolved after 30 years of manufacturing experience creating the most high efficient air compressor today in the market.

A proper designed compressor is customized to site conditions, consuming minimal required power. Compressors may be controlled by variable inlet guide vanes, variable diffusers, or both. The choice between the different control systems is based on variable flow rate demand, the discharge pressure and ambient conditions.



Small-sized compressor unit STC-GO (10)

Inlet flow from ca. 2,000–3,300 Nm³/hour and differential pressure from 0.4–1.9 bar.



Large-sized compressor unit STC-GO (80)

inlet flow from 40,000–80,000 Nm³/hour and differential pressure from and differential pressure from 0.4–1.5 bar.



STC-GO (10SV-GL285) Special application for flue gas desulfurization.

Flow 11,360 m³/hour–2.56 bar.

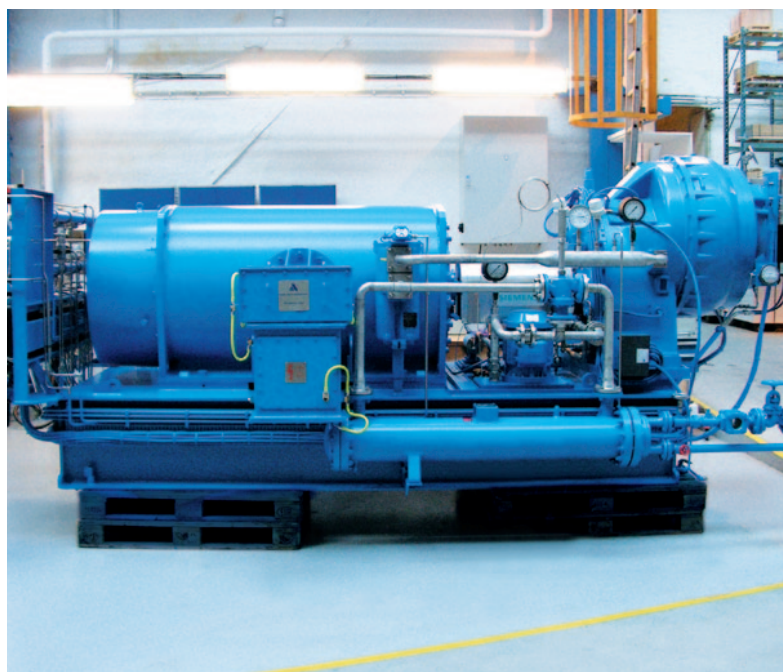

STC-GO (22V-GL315) Special application for sulfur recovery unit.

Mid-sized compressor unit STC-GO (22V-GL315) for constant air flow of 19,190 m³/hour–0.910 bar.

Different compressor control configurations:

Variable diffuser and inlet guide vane system

This design features the unique Siemens **Dual Point Control™** with both inlet guide vanes and variable diffusers, which ensures high efficiency operation – even at off-design conditions. This makes STC-GO especially suitable when operating requirements are characterized by substantial fluctuation in inlet temperature, discharge pressure and flow.

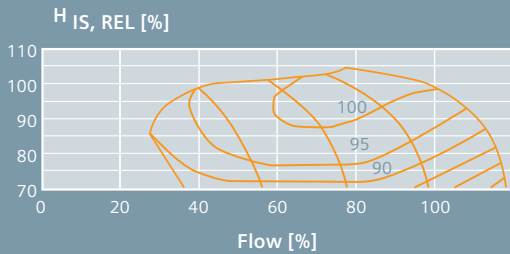

Variable diffuser system

Equipped with a variable diffuser system, STC-GO has relatively steep performance curves and is thus particularly well suited for high efficiency operation at relatively constant discharge pressure and inlet temperature.

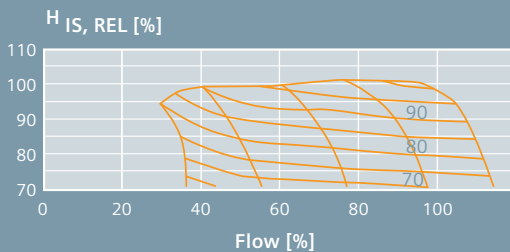

Inlet guide vane system

Equipped with an inlet guide vane system (IGV), STC-GO is the most efficient solution for applications demanding high flow rates. This design also complies with API standards and is highly suitable for industrial applications.

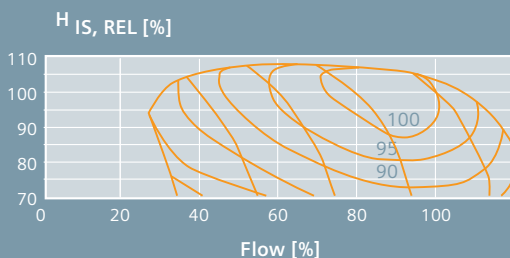

Inlet guide vane

Aerodynamic design

All components in the air stream are aerodynamically designed to minimize turbulence, thus streamlining flow through the compressor.

Variable diffuser system

The variable diffuser system controls the flow by adjusting the angle and consequently, the nozzle area of 17 to 21 diffuser vanes. The vanes are flow optimized, non-symmetrical airfoils, allowing adjustment of the nozzle area, while still maintaining an excellent efficiency throughout the entire operational range of the compressor. The vanes are arranged radially around the impeller.

Inlet guide vane system

The inlet guide vane system (IGV) controls the incidence angle of the inlet flow to the impeller, and thus influences the relative speed of the air. This allows the adjustment of the delivered head from the compressor and optimization of power consumption according to changes in operational parameters such as inlet temperature, outlet pressure, etc.

The Impeller:

The core of the compressor is the impeller with backward leaning blades angled according to regulation and milled from a solid forged piece of high grade aluminum alloy

Diffusor vanes

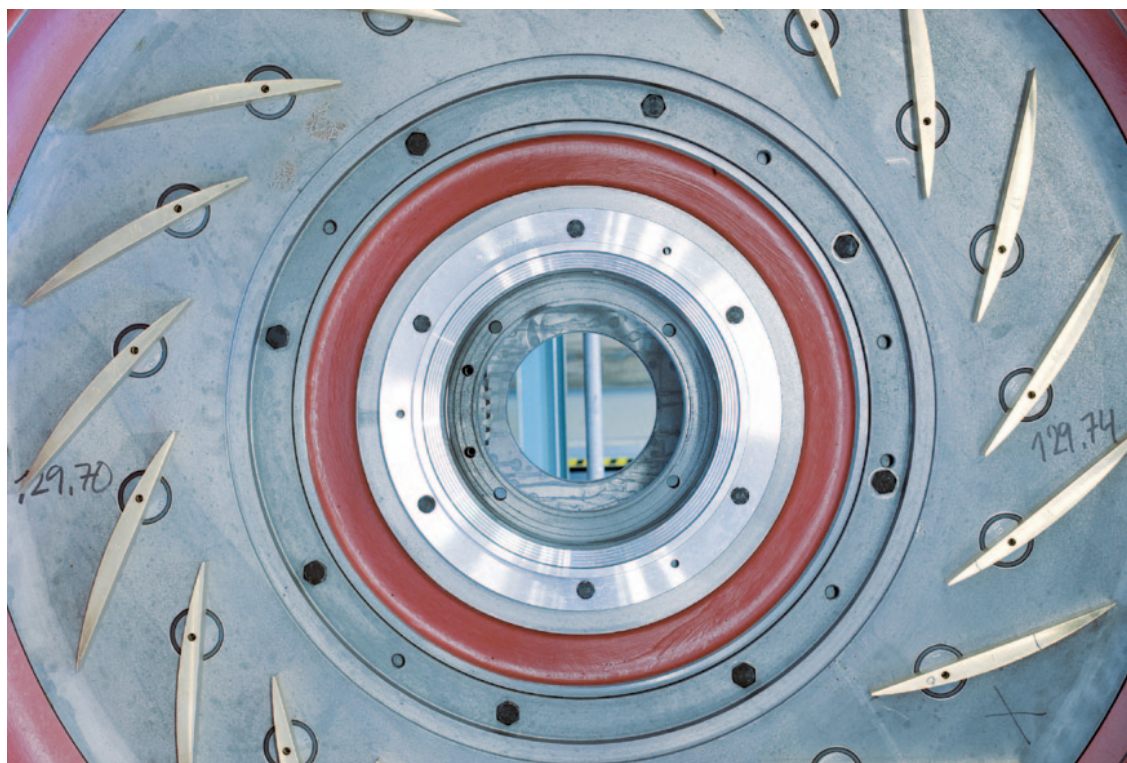

(originating from the aircraft industry), with an optimal weight/strength ratio. Siemens easily customize the design of the semi-open three-dimensional impeller by means of 3-dimensional simulation software (CFD Computer Fluid Dynamic Simulation) to meet individual plant requirements. The impeller design is based on an extensive database comprising full factory tests of more than 7,000 compressors as well as full scale tests and finite element analysis.

Inlet air is continuously and automatically pre-rotated by 13 to 24 non-symmetrical airfoils, arranged radially around the concentric inlet, thus maximizing efficiency throughout the operational range. The vanes are supported at both ends, an unusually strong and long-lasting configuration.

Mechanical design

The STC-GO series consist of single-stage compressors with integrated gearboxes. Compressor and gearbox are standard, fully integrated with vertical split and the pinion shaft above the drive shaft. The design is compact and easy to maintain. All gearwheels are customized according to compressor configuration.

Different gear types for different requirements

Siemens offers several different combinations of air-ends and gearboxes. Selection depends on the capacity, required power and type of driver. All gearboxes share similar heavy-duty design features for long and low maintenance operation.

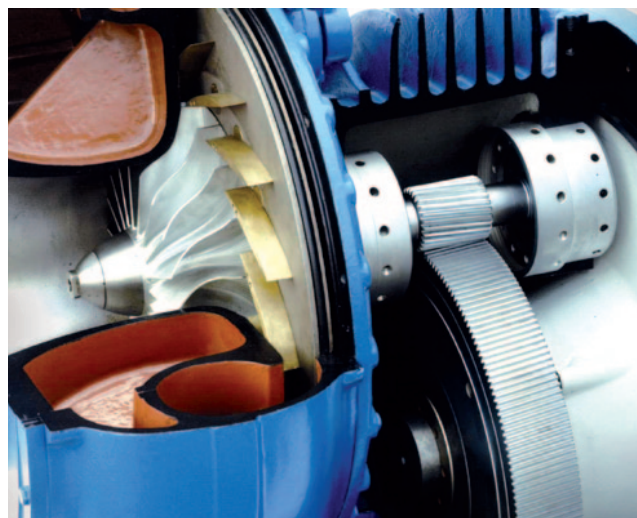

Ball bearing unit with helical gear and diffuser vanes for optimal efficiency

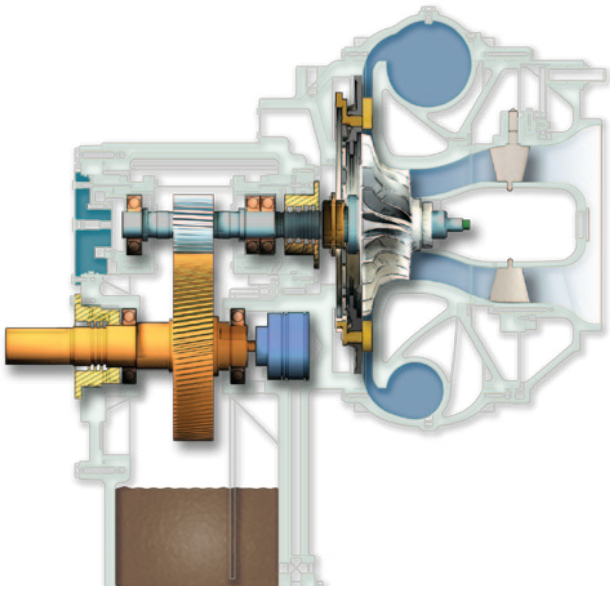

Model GK gearbox

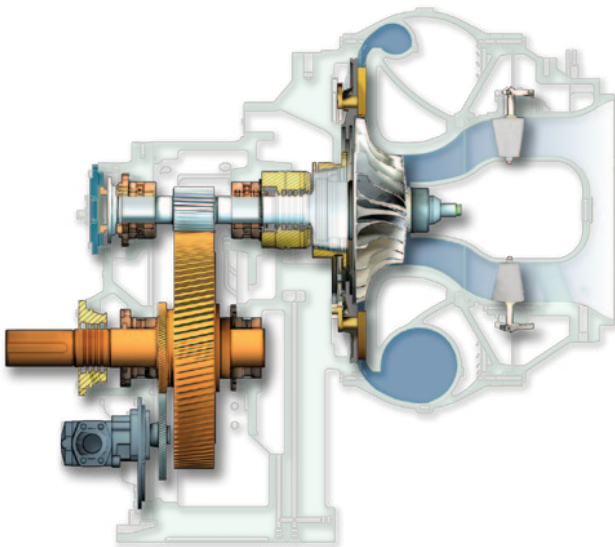

Model GL gearbox

GL-gear type series

The gears are helical cut from high grade steel alloy, case hardened and grinded to close tolerances. The bearings are hydrodynamic multi-pad bearings with forced oil lubrication. The designed bearing lifetime is 100,000 operational hours.

The design ensures easy access to vibration and temperature probes, which can be equipped optionally. The air and oil seals are non-contact labyrinth type. Gears and bearings are pressure lubricated by electrically and mechanically driven oil pumps.

The GL-gearboxes allows for higher flow and higher pressure within the range of STC-GO compressors and extend the maintenance intervals.

GK-gear type series

Aeration installations in smaller decentralized wastewater treatment plants often require special needs as regards compressor design and performance. The GK series are ideal for small-scale plants, because they offer a particularly compact design, with an integrated gearbox equipped with ball bearings lubricated by an integrated oil pump.

Special gear type series

The special GC-gear type is a planetary two stage co-axial gearbox for diesel or gas engine drivers, well suited for applications such as methane recovery processes. This type of gearbox is designed for increased torsional forces originating from the driver.

Efficiency by control

The efficiency of the aeration equipment ultimately depends on the control system.

The Siemens compressors are provided with safeguards and monitors for long-term, trouble free operation. Other instruments are available to monitor compressor operation and include vibration and bearing temperature monitors that are generally used on larger units. Maintenance status monitors are available for inlet air filters, oil filters, oil reservoir level, and reverse rotation.

Local Control

The Siemens local control panel (LCP) is specially designed for monitoring and controlling the STC-GO compressor with diffuser and inlet guide vanes (IGV).

Standard features:

- Control panel mounted on-skid or off-skid
- Control is provided by an internal Siemens PLC type S7-300 with job customized software
- Equipped with touch panel operator interface with B/W or colour screen
- Emergency stop push button
- Factory tested
- Protection class IP54, colour RAL7032
- Power supply according to specific requirements
- PROFIBUS communication
- Multilanguage interface

The local control panel is also provided with contactors for auxiliary equipment, such as

- Actuator for the blow-off valve
- Electric motor for the lube oil pump
- Electric motor for the air/oil cooler fan (if any)
- Servomotor for the variable diffuser
- Servomotor for the Inlet Guide Vane system (if any).

Special features:

Systems may be designed to accommodate specific client needs, for instance:

- Different PLC platforms
- Other network communication: PROFIBUS DP, Ethernet, MODBUS
- Housing in EEx certified enclosures of IP65 for hazardous area applications
- Modification for tropical environment
- Remote online support via GSM modem
- Trending of operational data

Vibration and monitoring devices

STC-GO compressors for municipal and industrial applications can be equipped with vibration detection and monitoring devices:

- Accelerometer offers vibration detection and monitoring, the analogue signal is connected directly to the PLC in the LCP
- Proximity probes for radial and axial shaft vibration monitoring

Master control

The master control panel (MCP) is designed for automatically controlling the air supply from a compressor group arrangement from 2 up to 15 STC-GO compressor units. With the MCP control using the highly efficient cascade control philosophy, the process is constantly provided with the right amount of oxygen.

This kind of regulation ensures:

- Maximum efficiency and lower energy consumption
- Accurate control – even under fluctuating conditions
- Priority control allowing the turbo compressors to equalize their working hours

MCP single overview

- Easy overview of each compressor's operational status
- Single overview for the operator on the complete compressor system showing all events and system messages
- Direct indication of main discharge pipe pressure and set-point
- All critical functions and settings are password protected



Control panel

Details Compressor Station

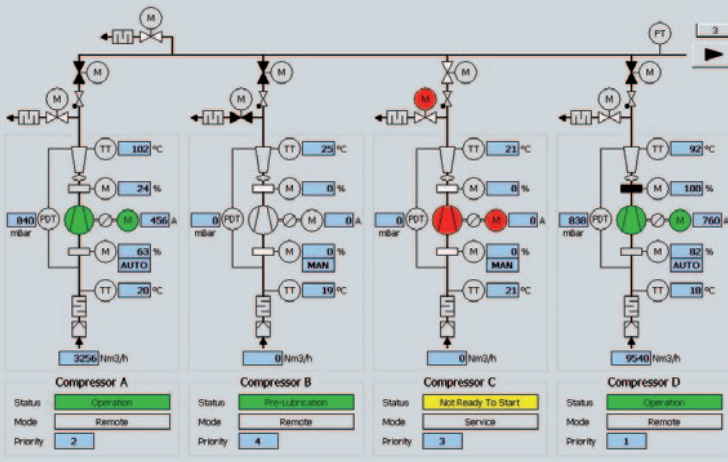

MCP single overview

Standard features:

- Control panel installed remotely
- Control by Siemens PLC S7-300 system
- Equipped with touch panel interface with B/W or optional color screen
- Factory tested before delivery
- Protection class IP54
- Power supply: According to customer requirements
- Multi-language interface
- Profibus communication to DCS system

Special features:

- Systems can optionally be designed to accommodate specific client needs, like:
- Easy connection to DCS/SCADA systems via Profibus DP, TCP/IP, Siemens Ethernet or Modbus RS485
 - System input/output for remote monitoring and control via SCADA
 - Different PLC platforms
 - Process trending
 - Redundancy requirements
 - Remote online support via GSM modem
 - Different sizes and materials for special applications
 - Housing in EEx certified enclosures of IP65 for hazardous area applications
 - Modification for tropical environment

Total Integrated Control

The next step for efficient control is the Air Bio Control system (ABC). Siemens can provide overall control and monitoring of the complete aeration system as one highly efficient, integrated unit. This includes control of the blowers, air flow control valves, air header blow-off valve, flow meters, dissolved oxygen and ammonium sensors.

The prime advantages of the system solutions include:

- Single-source responsibility
- System integration
- Greater overall efficiency
- Better control and smoother operation
- Avoiding interface issues
- Start-up and fine tuning
- Greater system reliability
- On-line support via modem (wireless or PSTN)

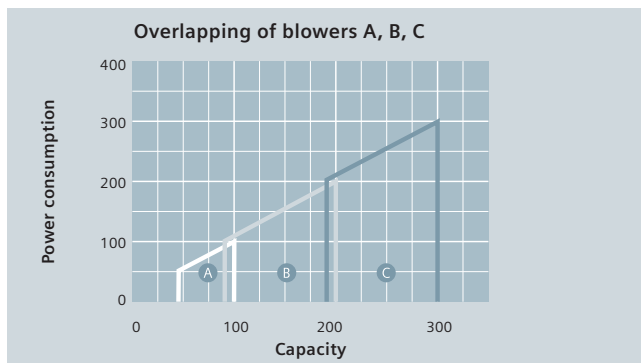

Testing

Standard Shop Test

Each compressor core unit is tested in our advanced test-rigs in accordance with our Standard Shop Test specification. The test-rigs are certified every year according to ISO 9001 and the calibration procedures are conducted at regular intervals according to ASME, ISO and API international standards.

During the Standard Shop Test, each compressor is operated at maximum design load for 3–10 operating hours, depending on the compressor type. The test procedures have been developed during decades of testing thousands of turbo-compressors and must fulfill the following purposes:

- Provide data over the entire specified operational range for the quality approval.
- Provide data for the automated power saving program with variable diffuser and inlet guide vane system.
- Provide specific and statistical data as feedback for the compressor design program.
- Provide to the customer documentation of the performance data and the performance range in the form of a graphic presentation.

Specifically during the Standard Shop Test are performed the followings:

Mechanical/Operational test

The lubricating-oil system is put into operation and the safety controls are checked and adjusted.

Initially the compressor is running at low load and special attention is paid to vibrations, the temperature rise of the bearing covers and the labyrinth seal flanges. The housings, flanges, and pipes, including the lube oil system, are checked for tightness.

Vibration measurements

According to ISO 10816, each compressor is run at maximum load and the vibration velocity is recorded within the range 10–1,000 Hz.

Noise measurements

According to ISO 3746, the sound-pressure measurements are recorded and an engineer evaluates the test data in relation to the specified data. A noise certificate can be issued on customer request

Performance test

- Heat balance test
By establishing a total energy balance for the compressor, by measuring all the losses and adding them to the energy input to the compressed gas.

- Torque meter test

By measuring the torque using a precision torque meter and the rpm of the driver.

- Electric motor test

By performing an energy balance on the driver in accordance with the appropriate test codes for the particular type of machine.

Additional testing

In addition to the mandatory tests Siemens offers to customers an optional testing portfolio.

Witness test

The test will be conducted by an experienced engineer in cooperation with the test-bed foreman according to international standards. The complete test procedure is witnessed either by the customer itself or a third party, i.e. an inspector from an independent and neutral inspection company.

Certified test

When the client is not in the position to attend the witness test a certified test can be offered. An experienced test engineer will conduct this test. Test log sheets will be signed by the test engineer certifying specified test points selected by the customer.

National and International Test Standards

Siemens' compressor-testing procedures, as well as the testing equipment, instrumentation, and calibration are in conformity with the national and international norms of testing turbo-compressors:

ISO 5389-2, Dec. 2005:

Turbo compressors – Performance Test Code

PTC 10 – 1997

Performance Test Code on Compressors and Exhausters

API Standard 672 fourth Edition, March 2004:

Packaged, Integrally Geared Centrifugal Air Compressors for Petroleum, Chemical, and Gas Industry Services

EN ISO 5167-1, 2003/EN ISO 5167-2, Jan. 2004:

Measurement of Fluid Flow by Means of Pressure Differential Devices

ISO 10816-1, 1995:

Mechanical Vibration

ISO 3746, 1995

Acoustics – Determination of Sound Power Levels of Noise Sources Using Sound Pressure

EN ISO 9001, 2000

Quality Management Systems- Fundamentals and Vocabulary.

Published by and copyright © 2012:

Siemens AG

Energy Sector

Freyeslebenstrasse 1

91058 Erlangen, Germany

Siemens AG, Energy Sector

Oil & Gas Division

Wolfgang-Reuter-Platz

47053 Duisburg, Germany

For more information, please contact
our Customer Support Center.

Phone: +49 180 524 70 00

Fax: +49 180 524 24 71

(Charges depending on provider)

E-mail: support.energy@siemens.com

Oil & Gas Division

Order No. E50001-G420-A121-V1-4A00

Printed in Germany

Dispo 34806, c4bs 74889, bdk xxxxxx,

P WS 03123.

Printed on elementary chlorine-free bleached paper.

All rights reserved.

Trademarks mentioned in this document are the property
of Siemens AG, its affiliates or their respective owners.

Subject to change without prior notice. The information in
this document contains general descriptions of the technical
options available, which may not apply in all cases.

The required technical options should therefore be specified
in the contract.